

# Installation Information

No. 4-421  
April, 1997



# Heavy Duty Series Eaton® Pump Controls Neutral Lockout Switch Kits

Eaton Corporation  
**Hydraulics Division**  
15151 Hwy. 5  
Eden Prairie, MN 55344  
Telephone 612/937-9800  
Fax 612/937-7130

Eaton Ltd.  
**Hydraulics Division**  
Glenrothes, Fife  
Scotland, KY7 4NW  
Telephone 01-592-771-771  
Fax 01-592-773-184

Copyright Eaton Corporation, 1997  
All Rights Reserved  
Printed in USA

## Disassembly

### Neutral Lockout Switch

1. Disconnect wiring from the lockout switch.
2. Loosen hex set screws in adapter and remove neutral lockout switch from adapter.
3. Remove neutral lockout adaptor from servo control valve assembly.

## Neutral Lockout – Switch Identification

1. Remove the switch from the adaptor.
2. Connect a test light with a 12 Vdc power source or a multimeter to the switch terminals. Polarity does not matter. See figure 1-2. If a multimeter is used, set to “ohms” and note that our reference to light “On” is the same as zero ohms and light off is the same as infinite ohms.
3. If the light is off when the ball in the end of the switch is not depressed but comes on when the ball is depressed, then it is a normally open (N/O) switch.

Caution: Do not depress the ball beyond a point where it is flush with the housing. Permanent damage to the switch could occur.

4. If the test light comes on when the ball is not depressed, but goes off when the ball is depressed, it is a normally closed (N/C) switch.

## Neutral Lockout Switch Kits

990661-000 Screw Terminal N/C, Neutral Lockout Switch Kit	990721-000 Screw Terminal N/O, Neutral Lockout Switch Kit	990720-000** Delphi Packard, N/C, Neutral Lockout Switch Kit	990754-000** Delphi Packard, N/O, Neutral Lockout Switch Kit
109791-001 (1) N/C Neutral Lockout Switch (If purchased separately order 990757-000 Kit ❖ )	110083-000 (1) N/O Neutral Lockout Switch (If purchased separately order 990758-000 Kit ❖ )	109089-000 (1) N/C Neutral Lockout Switch (If purchased separately order 990759-000 Kit ❖ )	110536-000 (1) N/O Neutral Lockout Switch (If purchased separately order 990760-000 Kit ❖ )
102149-019* (2) Socket Set Screw	102149-019* (2) Socket Set Screw	102149-019* (2) Socket Set Screw	102149-019* (2) Socket Set Screw
107977-000* (1) Adaptor	107977-000* (1) Adaptor	107977-000* (1) Adaptor	107977-000* (1) Adaptor

❖ When ordering switch kits with adaptors the threads of the switch will have a high temperature water resistant grease applied to the threads at the factory. Apply the grease at installation if ordering just a switch.

\* Items may be purchased without Switch as Part of Kit 990650-000 see below

990650-000 Neutral Lockout Switch Adaptor Kit
102149-019 (2) Socket Set Screw
107977-000 (1) Adaptor

\*\*Note: Mating connector and terminals are not provided they are manufactured by Delphi Packard:

Connector	P/N 1201 5792
Terminals	P/N 1208 9040
Cable Seal	P/N 1201 5323

**CAUTION** Unexpected movement or operation of equipment may cause serious injury or death. Make sure the battery is disconnected and the engine is not running. Make sure the parking brake is engaged and other peripheral equipment is disengaged.

NOTE: Hydraulic fluid can leak from the servo control valve assembly when removing the neutral lockout switch and adaptor assembly. First shut off the hydraulic reservoir to the pump and drain the hydraulic fluid from the pump case to a level below the servo control valve assembly.

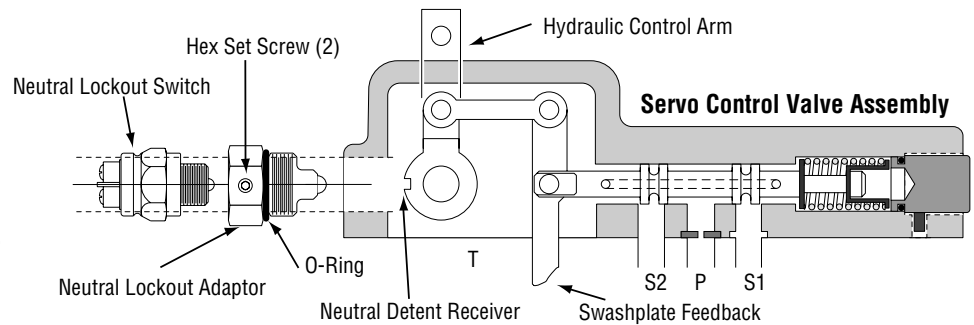

Figure 1-1

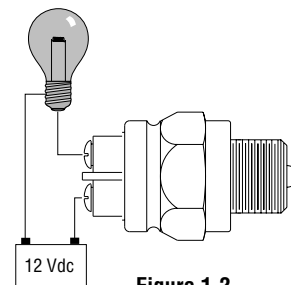
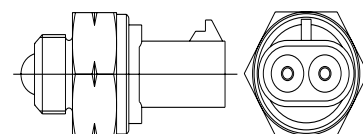

Figure 1-2  
Screw Terminal Switch



Switch with Delphi Packard Connector

# Reassembly Normally Closed

**Note:** Reassembly may be done with the Servo Control Valve Assembly on or off the main hydrostatic pump. The final check of the switch must be done on the pump with all the linkage attached and before engine start-up.

## Normally Closed (N/C) Neutral Lockout Switch

1. With the switch removed from the adapter, install the adapter into the control assembly. Torque the adapter to 60-72 N-m (44-53 lbf-ft).
2. With the adaptor installed, proceed and install the neutral lockout switch into the adapter, again refer to figure 1-1.
3. The adjustment procedures for the switch are as follows;
  - (a). First apply a high temperature water resistant grease to the threads. Screw the switch in slowly, while moving the hydraulic control arm back and forth, until "detent" action is detected in the arm movement. See figure 2-1 . Back out the switch until the "detent" action is very slight. Then position the arm out of the detent position (figure 2 -2 ).
  - (b). Obtain a test light and 12 Vdc power source or use a multimeter. Multimeter use is described under "Switch Identification". Attach the leads from the test light to the switch. If the light does not immediately come on, back the switch out until it does.

(c). Screw the switch in until the light just goes off. Mark this as position "A" with two adjacent marks on the switch adapter. Refer below to figure 2-3. Move the control arm to the detent position and the test light should come back on.

(d). Leaving the control arm in the detent position, screw the switch in until the light just goes off. Mark this position "B" on the switch adjacent to the original mark on the adapter.

(e). Back out the switch one half the distance between "B" and "A". Refer to figure 2 -3. Torque either hex socket head set screw to 3.2 to 3.8 N-m [28 to 34 lbf-in.] One screw may be inaccessible and does not need to be tightened.

4. As a final precaution, test the switch by moving the machine's hydrostatic control handle to the neutral position – the light should be on. Move the control handle slightly out of the neutral position and the light should go off.
5. Remove test light, reattach original wiring to the Neutral Lockout Switch and put servo control valve assembly into operation.

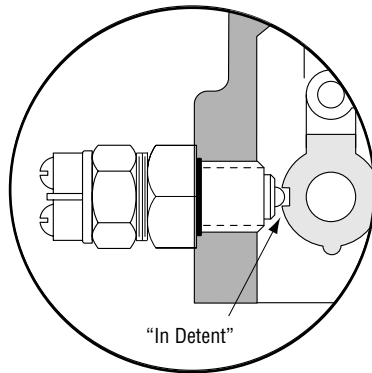

Figure 2-1

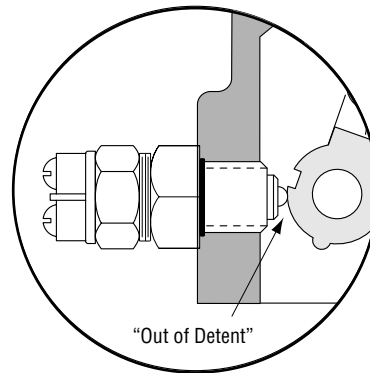

Figure 2-2

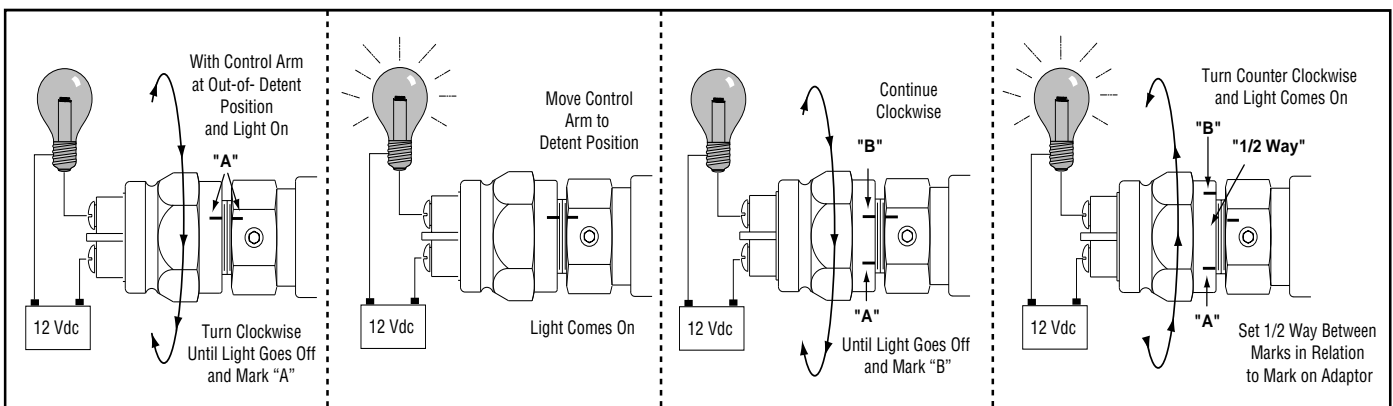

Figure 2-3

# Reassembly Normally Open

## Normally Open (N/O) Neutral Lockout Switch

1. With the switch removed from the adapter, install the adapter into the control assembly, refer to figure 1-1. Torque the adapter to 60-72 N-m (44-53 lbf-ft).
2. With the adaptor installed proceed and install the neutral lockout switch into the adapter.
3. The adjustment procedures for the switch are as follows;

(a). First apply a high temperature water resistant grease to the threads. Screw the switch in slowly, while moving the hydraulic control arm back and forth, until "detent" action is detected in the arm movement. See figure 3-1. Back out the switch until the "detent" action is very slight. Then position the arm out of the detent position. See figure 3-2.

(b). Obtain a test light and 12 Vdc power source or use a multimeter. Multimeter use is described under "Switch Identification". Attach the leads from the test light to the switch. If the light comes on, back the switch out until it goes out.

(c). Screw the switch in until the light just comes on. Mark this as position "A" with two adjacent marks on the switch and adapter. Refer to figure 3-3 below. Move the control arm to the detent position and the test light should go back off.

(d). Leaving the control arm in the detent position, screw the switch in until the light just comes on. Mark this position "B" on the switch adjacent to the original mark on the adapter.

(e). Back out the switch one half the distance between "B" and "A". Refer to figure 3-3. Torque either hex socket head set screws to 3.2 to 3.8 N-m [28 to 34 lbf-in.] One screw may be inaccessible and does not need to be tightened.

4. As a final precaution, test the switch by moving the machine's hydrostatic control handle to the neutral position – the light should be off. Move the control handle slightly out of the neutral position and the light should go on.
5. Remove test light, reattach original wiring to the Neutral Lockout Switch and put servo control valve assembly into operation.

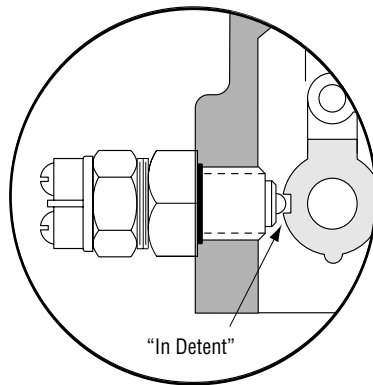

Figure 3-1

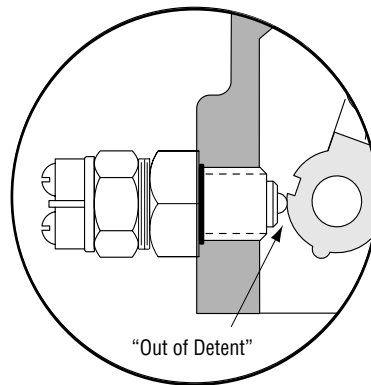

Figure 3-2

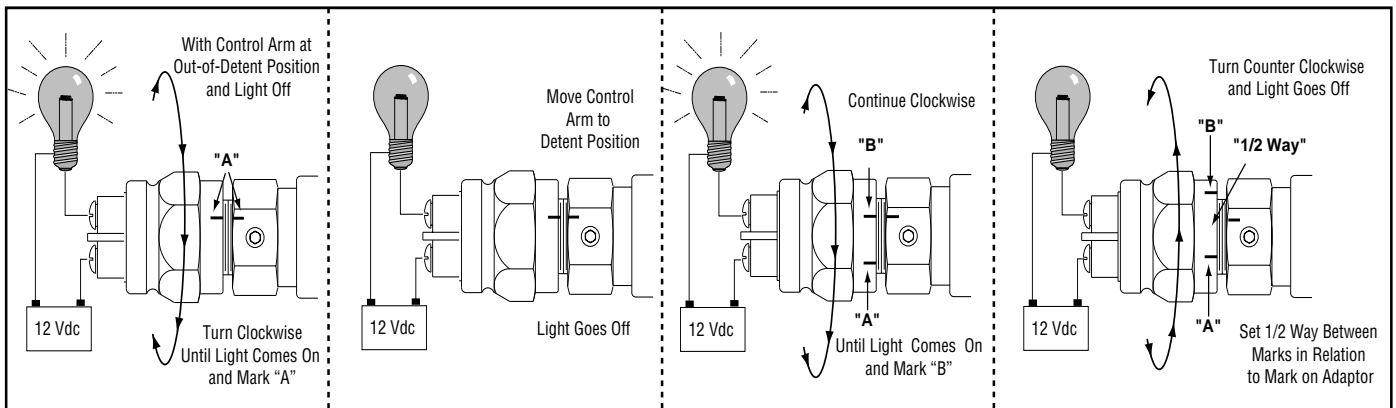
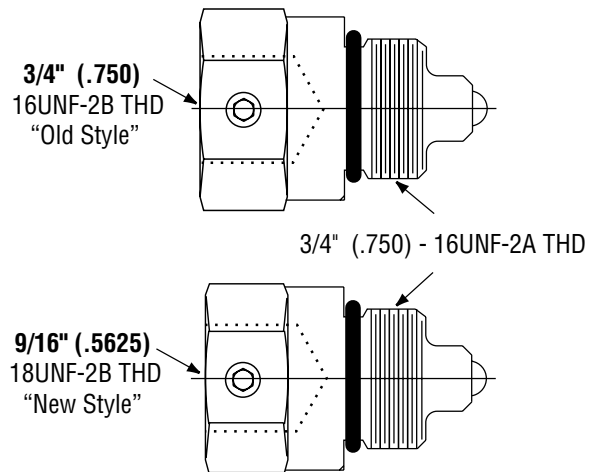

Figure 3-3

## Neutral Lockout – Adaptor Identification

1. Please note that Eaton has manufactured two sizes of Neutral Lockout Adaptors. Check to be sure which size you are working with.
2. The “old style” adaptor accepts a 3/4" threaded switch, and the new style accepts a 9/16" threaded switch. See figure 4-1.
3. When ordering a replacement switch kit the appropriate adaptor is included.

**Note: New switches are 9/16" threads and will not mate with older style adaptors.**



**Figure 4-1  
Neutral Lockout Adaptors**